

*Do you have a front-to-back
solution for microwave circuit designs?*



HP MICROWAVE CIRCUIT DESIGNER

STREAMLINING THE DESIGN PROCESS WITH TOP-DOWN DESIGN

To meet the increasing market demands placed on consumer and commercial communications, design engineers must leverage every possible competitive advantage. That's why many leading technology companies rely on HP EEsof's design automation tools to deliver high-performance products with lower cost in fewer design turns.

HP Microwave Circuit Designer offers engineers a complete front-to-back solution for developing today's advanced microwave circuits. This approach lets designers start at the system level with specification partitioning and work down to the circuit level using a broad variety of powerful simulators.

With the right combination of sophisticated simulation technology and accurate models, designers can maximize their productivity and product performance. This diverse set of design tools lets engineers bring their best ideas into reality with faster time to market.

MAXIMIZING PRODUCTIVITY

As circuits and design processes increase in complexity, EDA tool integration becomes a critical factor. To enable full characterization and optimization of designs under multiple conditions, HP Microwave Circuit Designer provides an integrated solution that includes frequency- and time-domain circuit simulation as well as electromagnetic field analysis. In addition, yield analysis and discrete value optimization help speed designs into production with maximum performance and yield.

DESIGN SYNCHRONIZATION

Through design synchronization, the layout has a one-to-one correspondence with the schematic so that modifications to the layout are automatically reflected in the schematic. This unique capability allows designers to create a layout directly from the schematic. Circuit simulations are hierarchically tied to both the schematic and the physical layout to provide fast, accurate analysis at all phases of the design process. When the layout is finished, designs are quickly transferred to manufacturing using industry-standard file formats.

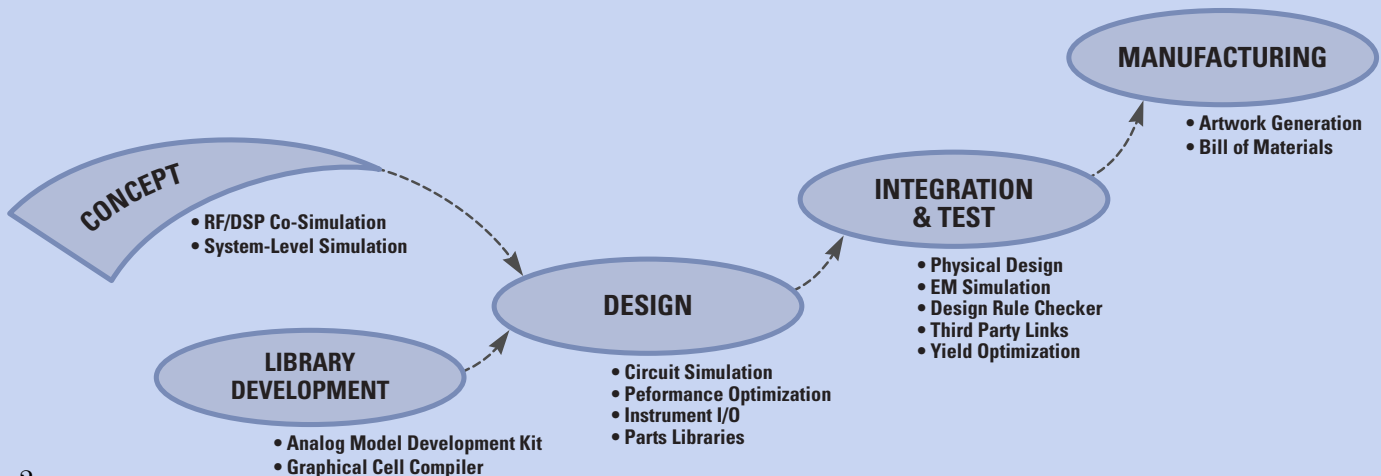



COMBINING SYSTEM, CIRCUIT, AND EM ANALYSES

One of Microwave Circuit Designer's most powerful features is the ability to directly embed linear and nonlinear circuits in higher-level microwave system designs. With a full range of complex modulated signal sources available, engineers can test their circuits under real-world conditions.

For example, the nonlinear circuit simulator first optimizes an amplifier's performance for maximum output power and minimum input return loss. Then, with the amplifier embedded in a higher-level system, performance is re-evaluated. Using a complex modulated signal, designers can accurately predict spectral regrowth and associated adjacent channel power at the amplifier's output.

The electromagnetic effects of parasitic coupling and dispersion can be included in the circuit design phase. Electromagnetic analysis results of planar and 3D circuits can be included in the circuit simulation of complex microwave circuits.

MANAGING DESIGNS EASILY AND EFFECTIVELY

The collective work of an entire microwave design team can be managed as a single project. Or, team members can use separate project directories so that multiple designs (schematic and layout) can proceed in parallel and then be merged together in a single higher-level design. Finally, designers working in any project directory can share a common set of custom libraries and subcircuits.

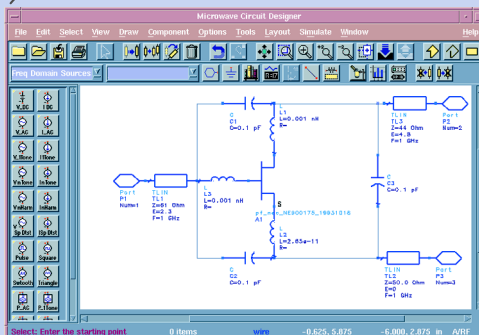
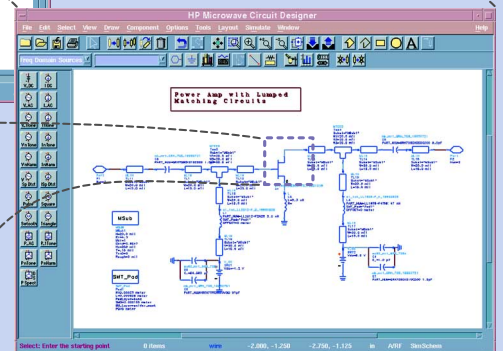
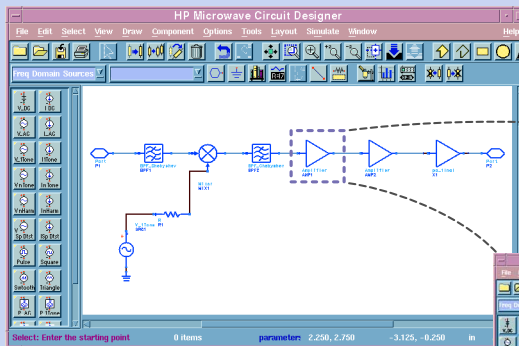

Nested design files let you group system, circuit, and subcircuit files together.

A COMPLETE FRONT-TO-BACK SOLUTION FOR ADVANCED MICROWAVE DESIGNS

LEVERAGING MULTIPLE SIMULATION TECHNOLOGIES

Microwave Circuit Designer provides a complete spectrum of simulation technologies ranging from frequency- and time-domain circuit simulation to electromagnetic field simulation. Together, these technologies let designers fully characterize and optimize designs under multiple conditions.

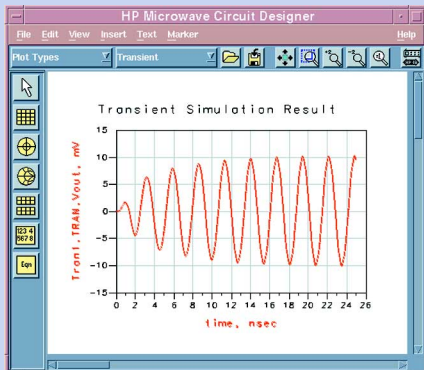

With yield analysis and discrete value optimization, designers can test the sensitivity of a design to component tolerances. Physical design tools generate the layout for bringing designs to prototype, final artwork, or merging with analog and digital circuitry on a single board.

Links to test instrumentation such as network analyzers, spectrum analyzers, and oscilloscopes make data collection quicker and simpler than ever. Since real-world signals and measurements are available, it is easy to compare measured versus simulated data.

LINEAR AND NONLINEAR STEADY-STATE ANALYSIS

Linear simulation is the most frequently required analysis for the design of LNAs, filters, and passive microstrip structures, such as matching networks. Gain and noise figure circles help predict amplifier performance, while S-, Z-, Y-, and H-parameters provide accurate subcircuit characterization. For circuits with nonlinear devices, the DC bias point is calculated so that a small-signal analysis can be performed.

Nonlinear simulation using the harmonic balance technique extends the capabilities of linear simulation to include nonlinear effects such as compression in amplifiers, mixer noise, and nonlinear amplifier noise.

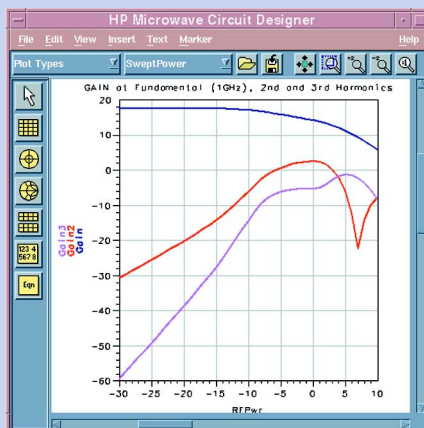

Simulate nonlinear effects such as oscillator start-up transients, amplifier compression, and multi-tone inputs.

Use Microwave Circuit Designer's extensive library of microwave system, circuit, and layout elements to define the prototype from the bottom up. System-level behavioral elements include mixers, filters, amplifiers, and switches as well as models for microstrip, stripline, coplanar waveguide, and suspended substrate components.

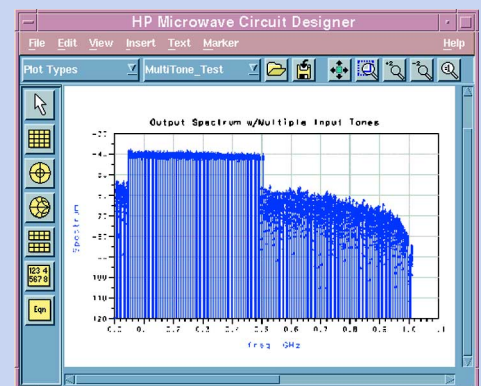

COMPLEX MODULATED SIGNAL ANALYSIS

As a hybrid time-frequency-domain simulator, Circuit Envelope is ideal for analyzing complex, digitally-modulated RF signals in circuits and subsystems. This patented technology is well suited to modeling mixer high-order intermodulation distortion, and mixer spectral regrowth, as well as designing voltage-controlled oscillators, amplifier turn-on harmonics, and amplifier spectral regrowth. Unlike SPICE, Circuit Envelope can include dispersive distributed models to accurately analyze high-frequency effects.

TRANSIENT ANALYSIS

The high-frequency SPICE transient simulator can analyze the start-up effects of oscillators, stepped RF responses in amplifiers and other active circuits, and coupling of high-speed interconnects. For greater accuracy, the convolution simulator extends the capabilities of high-frequency SPICE. Convolution analysis is ideal for time-domain simulation of circuits that contain frequency-dependent data, such as S-parameter files or dispersive losses.



Data extraction is simplified with direct links to measurement instrumentation including spectrum analyzers, oscilloscopes, and network analyzers, such as the HP 8753.

EM ANALYSIS AND DESIGN REFINEMENT

Electromagnetic (EM) field simulation of components and circuits adds accuracy, enabling engineers to include models that are unavailable in the standard libraries. HP Momentum analyzes the high-frequency effects in arbitrary planar circuits embedded in multi-layer substrates. Simulation results are readily available to circuit simulators for inclusion in larger circuits and systems.

HP High-Frequency Structure Simulator (HP HFSS) simulates the high-frequency effects in arbitrarily-shaped, 3D structures. Typical 3D circuits modeled by HP HFSS include coax-to-microstrip transitions, packages and integrated capacitors. HP HFSS is available separately, but its S-parameter simulations are ready for use in any Microwave Circuit Designer project.

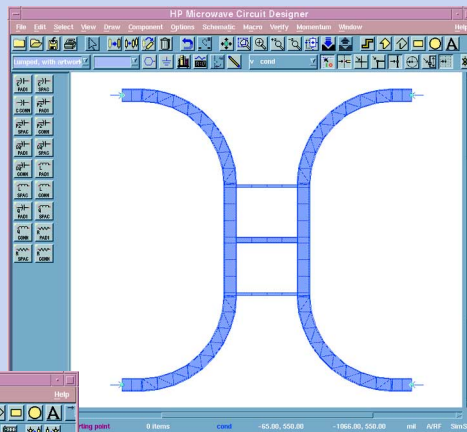
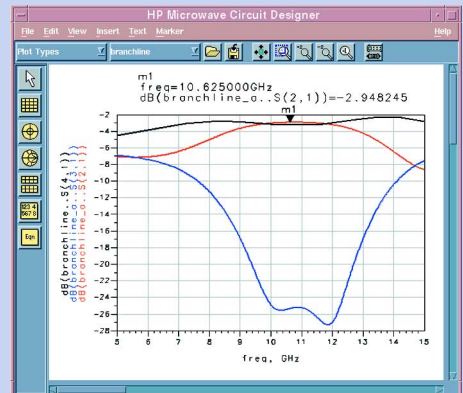

EM field simulators are traditionally used for analyzing and verifying designs, typically near the end of the design phase. HP EEsos's latest electromagnetic field optimization software offers automatic design refinement combined with EM accuracy. After the engineer specifies performance goals, the design parameters are then optimized and the final design is generated.

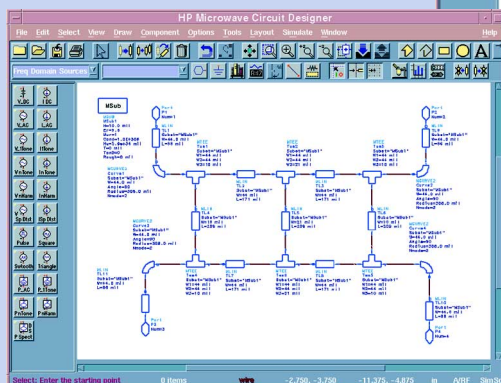

From the Microwave Circuit Designer layout window you can launch the optional HP Momentum EM simulator to precisely analyze complex structures.

IMPLEMENTING THE PHYSICAL DESIGN

HIGH-FREQUENCY BASED LAYOUT EDITOR

Microwave Circuit Designer layout is the cornerstone of a physical design environment for complex MMIC circuits. Each component can have a layout representation in addition to a schematic representation and an electrical model. The layout editor is fully integrated in the design environment and supports powerful design tools such as electromagnetic analysis, parameterized model generation, and design verification.

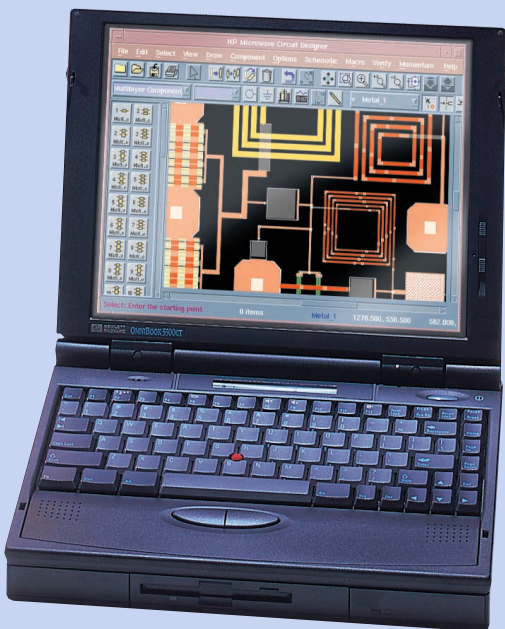

Microwave Circuit Designer easily captures detailed MMIC layouts while maintaining associations to schematic components.

GRAPHICAL CELL COMPILER

The Graphical Cell Compiler (GCC) enables designers or foundries to create complex parameterized artwork without in-depth programming knowledge. Parameterized layouts can easily be compiled using macros such as stretch and move, flip and rotate, or repeat and polar. The GCC can generate MMIC foundry models for FETs, inductors, resistors, and capacitors.

DESIGN RULE CHECKER

With the Design Rule Checker (DRC), engineers can verify if layouts follow design rules before fabricating a prototype. When design rules are violated, there is an increased risk that the circuit will not operate properly. The DRC is easily customized to fit any fabrication process through a user-friendly graphical interface. After running the rule check, the program shows a list of errors, each highlighted on the layout.

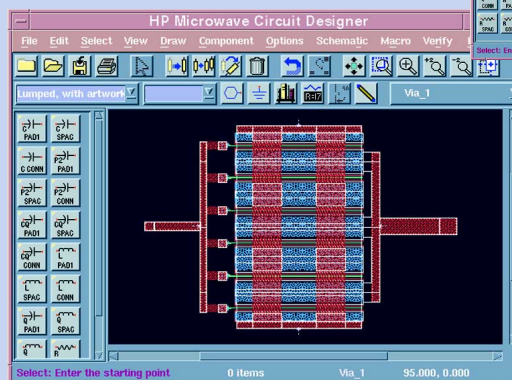

Using the Graphical Cell Compiler, static structures may be imported using the GDSII format and converted into parameterized structures such as this FET definable in terms of the number of fingers and finger width.

DEVICE MODELING, CHARACTERIZATION, AND ANALYSIS

HP EEsOf provides two tools for the modeling, characterization, and analysis of active devices. The HP Active Physical Device Simulator (HP APDS) offers fast physical device simulation for MESFETs and HEMTs and generates a nonlinear Root model.

The Integrated Circuit Characterization and Analysis Program (HP IC-CAP) automates the process of accurate device characterization by providing turnkey extraction modules for a wide range of popular device models. Because both HP APDS and IC-CAP are compatible with HP Advanced Design System, the models can be used with any Microwave Circuit Designer projects.

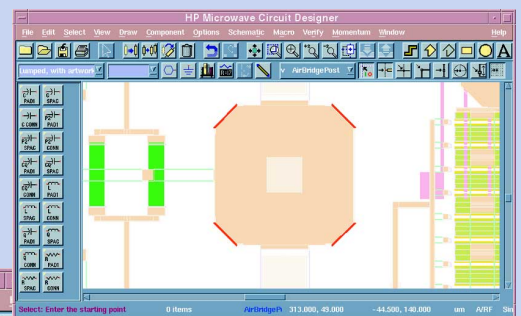

Design rule checking captures errors (red areas at corners) in individual object construction or in placement of objects relative to each other.

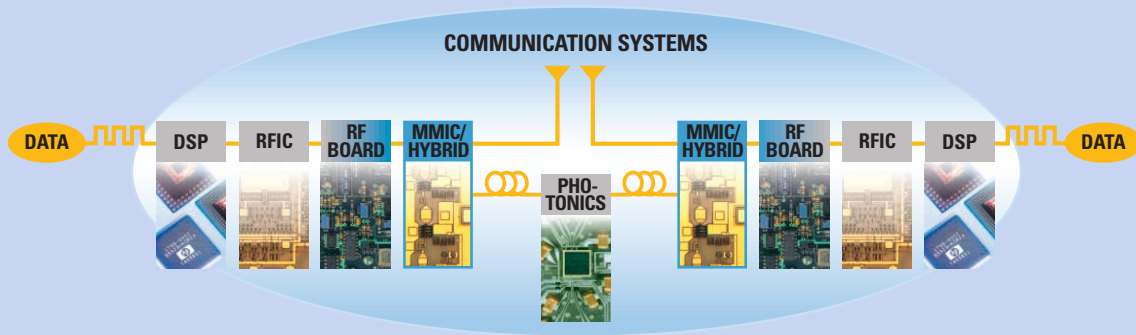

Microwave Circuit Designer is part of HP Advanced Design System, which lets you simulate the entire communications signal path from input bits to output bits—with powerful tools for RF board, DSP, RFIC, MMIC/hybrid, photonics, communications systems, and planar EM—all in a single design environment.

PERFORMANCE AND YIELD OPTIMIZATION

To produce linear and nonlinear circuits with optimal performance, designers can select from several powerful optimization technologies including gradient, random, and genetic algorithms. Discrete optimization is available for those parameters with a finite number of values. Optimization goals can be specified for virtually any measurable parameter, across frequency or even across swept parameter values.

Yield analysis characterizes the manufacturing yield of the design while yield optimization automatically adjusts parameter values to maximize yield. Electromagnetic optimization is also available, so designers can optimize layout geometries or 3D structures.

USER-DEFINED MODELS

Microwave Circuit Designer lets users create their own models with either a frequency-domain representation (such as S- or Y-parameters) or a time-domain representation (such as the current and charge equations for a GaAs FET). These models are interpreted—there is no need for compilation and linking—so Microwave Circuit Designer is an ideal environment for model prototyping.

GETTING THE MOST FROM YOUR DESIGN SOFTWARE

Leverage HP EEsof's broad expertise through custom solution services designed to improve engineering efficiency and productivity. From helping to streamline internal design processes to custom tailoring HP EEsof tools for specific applications, our consulting services team can help companies get the most out of all their design resources.

With HP EEsof product support, customers receive substantial software upgrades, application resources, manual updates, and engineering support via telephone, fax, email, and the web. International support facilities are staffed to meet specialized customer needs around the world.

To help users take advantage of the full power of their design tools, HP EEsof offers an extensive curriculum of training courses that cover product capability, design techniques, and real-world applications.

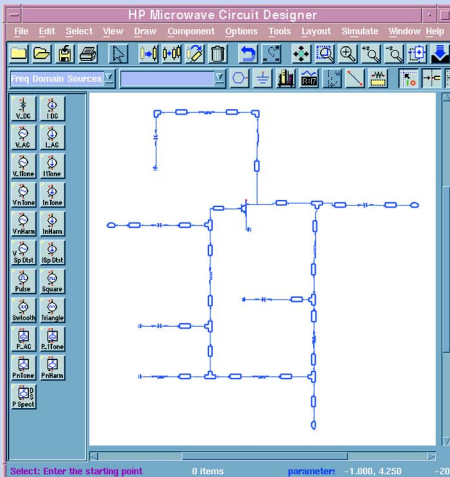
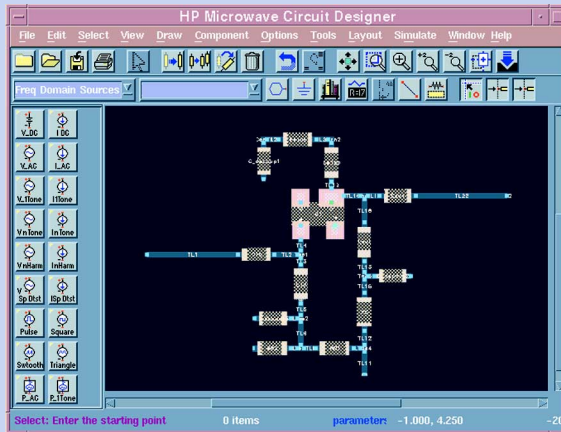

For those who require the run-time efficiency of a compiled model, the Analog Model Development Kit provides a user-friendly wizard that compiles and links model code and creates the symbols and parameter description files for use in the Microwave Circuit Designer environment.

Layouts may be automatically generated from existing schematics providing a 'correct by design' correspondence of schematic and layout elements.

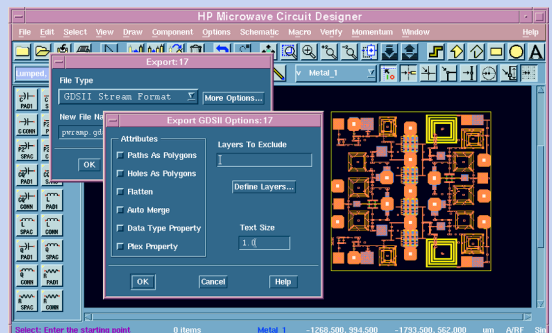

Physical design data can be easily output to a variety of convenient file formats, including Gerber, DXF, IGES, and GDSII files.

PRODUCT DESIGN SUITES



HP Microwave Circuit Designer combines leading edge high-frequency simulation and optimization technologies with accurate models and physical design tools tailored for microwave designers. These cost-effective solutions are available in both node-locked and network-licensed configurations on PC and UNIX systems, except where noted.

HP Model Numbers	
Microwave Circuit Designer*	E8910A
Design Environment	E8900A
Data Display	E8901A
Linear Simulator	E8881A
Harmonic Balance Simulator	E8882A
Microwave Transistor Library	E8952A
High-Frequency Diode Library	E8954A
Layout (optional)	E8902A
Microwave Circuit Designer Pro	E8911A/AN
Design Environment	E8900A/AN
Data Display	E8901A/AN
Linear Simulator	E8881A/AN
Harmonic Balance Simulator	E8882A/AN
Microwave Transistor Library	E8952A/AN
High-Frequency Diode Library	E8954A/AN
Statistical Design	E8824A/AN
Microwave Circuit Designer Premier	E8912A/AN
Design Environment	E8900A/AN
Data Display	E8901A/AN
Linear Simulator	E8881A/AN
Harmonic Balance Simulator	E8882A/AN
Circuit Envelope Simulator	E8883A/AN
Microwave Transistor Library	E8952A/AN
High-Frequency Diode Library	E8954A/AN
Statistical Design	E8824A/AN
Layout	E8902A/AN
Analog Model Development Kit	E8890A/AN
RF System Models	E8854A/AN
Optional Companion Tools	
HP HFSS Designer	E8930A/AN
APDS Design Suite	85290A/AN
IC-CAP Modeling Suite	85190A/AN

*This package is node-locked for the PC and has no expansion options.

THE COMPETITIVE ADVANTAGE

HP EEsof's EDA tools are developed for today's designers building tomorrow's microwave and communications products. From DSP and RFIC design to device modeling and consulting services, HP EEsof offers a full array of design tools to streamline your product development process.

United States

Hewlett-Packard Company
Test and Measurement Organization
5301 Stevens Creek Blvd., Bldg. 51L-SC
Santa Clara, CA 95052-8059
tel: (800) 452-4844 (toll free)

Canada

Hewlett-Packard Canada Ltd.
5150 Spectrum Way
Mississauga, Ontario L4W 5G1
tel: (905) 206-4725

Europe

Hewlett-Packard
European Marketing Centre
P.O. Box 999
1180 AZ Amstelveen
The Netherlands
tel: (31) 20-547-9900

Japan

Hewlett-Packard Japan Ltd.
Measurement Assistance Center
9-1, Takakura-Cho, Hachioji-Shi,
Tokyo 192, Japan
tel: 0120 421-345

Latin America

Hewlett-Packard
Latin American Region Headquarters
5200 Blue Lagoon Drive, 9th Floor
Miami, Florida 33126 U.S.A.
tel: (305) 267-4245/4220

Australia/New Zealand

Hewlett-Packard Australia Ltd.
31-41 Joseph Street
Blackburn, Victoria 3130
Australia
tel: (800) 629-485 (toll free)
fax: (61-3) 9899-3727

Asia Pacific

Hewlett-Packard Asia Pacific Ltd.
17-21/F Shell Tower, Times Square
1 Matheson Street, Causeway Bay
Hong Kong
tel: (852) 2599-7889
fax: (852) 2506-9233

<http://www.hp.com/go/hpeesof>

Data subject to change.
© 1998 Hewlett-Packard Company