

# 22

---

## The $z$ -Transform

In Lecture 20, we developed the Laplace transform as a generalization of the continuous-time Fourier transform. In this lecture, we introduce the corresponding generalization of the discrete-time Fourier transform. The resulting transform is referred to as the  $z$ -transform and is motivated in exactly the same way as was the Laplace transform. For example, the discrete-time Fourier transform developed out of choosing complex exponentials as basic building blocks for signals because they are eigenfunctions of discrete-time LTI systems. A more general class of eigenfunctions consists of signals of the form  $z^n$ , where  $z$  is a general complex number. A representation of discrete-time signals with these more general exponentials leads to the  $z$ -transform.

As with the Laplace transform and the continuous-time Fourier transform, a close relationship exists between the  $z$ -transform and the discrete-time Fourier transform. For  $z = e^{j\Omega}$  or, equivalently, for the magnitude of  $z$  equal to unity, the  $z$ -transform reduces to the Fourier transform. More generally, the  $z$ -transform can be viewed as the Fourier transform of an exponentially weighted sequence. Because of this exponential weighting, the  $z$ -transform may converge for a given sequence even if the Fourier transform does not. Consequently, the  $z$ -transform offers the possibility of transform analysis for a broader class of signals and systems.

As with the Laplace transform, the  $z$ -transform of a signal has associated with it both an algebraic expression and a range of values of  $z$ , referred to as the *region of convergence* (ROC), for which this expression is valid. Two very different sequences can have  $z$ -transforms with identical algebraic expressions such that their  $z$ -transforms differ only in the ROC. Consequently, the ROC is an important part of the specification of the  $z$ -transform.

Our principal interest in this and the following lectures is in signals for which the  $z$ -transform is a ratio of polynomials in  $z$  or in  $z^{-1}$ . Transforms of this type are again conveniently described by the location of the poles (roots of the denominator polynomial) and the zeros (roots of the numerator polynomial) in the complex plane. The complex plane associated with the  $z$ -transform is referred to as the  $z$ -plane. Of particular significance in the  $z$ -plane is the circle of radius 1, concentric with the origin, referred to as the *unit circle*.

Since this circle corresponds to the magnitude of  $z$  equal to unity, it is the contour in the  $z$ -plane on which the  $z$ -transform reduces to the Fourier transform. In contrast, for continuous time it is the imaginary axis in the  $s$ -plane on which the Laplace transform reduces to the Fourier transform.

The pole-zero pattern in the  $z$ -plane specifies the algebraic expression for the  $z$ -transform. In addition, the ROC must be indicated either implicitly or explicitly. There are a number of properties of the ROC in relation to the poles of the  $z$ -transform and in relation to characteristics of the signal in the time domain that often imply the ROC. For example, if the sequence is known to be right-sided, then the ROC must be the portion of the  $z$ -plane outside the circle bounded by the outermost pole. This and other properties are discussed in detail in the lecture.

### **Suggested Reading**

Section 10.0, Introduction, page 629

Section 10.1, The  $z$ -Transform, pages 630–635

Section 10.2, The Region of Convergence for the  $z$ -Transform, pages 635–643

Section 10.3, The Inverse  $z$ -Transform, pages 643–646

MARKERBOARD  
22.1

Discrete-Time  
Fourier Transform

$$x[n] = \frac{1}{2\pi} \int_{-\pi}^{\pi} X(\omega) e^{j\omega n} d\omega$$

$$X(\omega) = \sum_{n=-\infty}^{\infty} x[n] e^{-j\omega n}$$

LTI Systems  
impulse response

$$e^{j\omega n} \rightarrow H(\omega) e^{j\omega n}$$

$$\downarrow \mathcal{F}$$

$$h[n]$$

$$z^n \rightarrow \sum_{k=-\infty}^{\infty} h[k] z^{n-k}$$

$$z^n \rightarrow z^n \sum_{k=-\infty}^{\infty} h[k] z^{-k}$$

$$z = r e^{j\omega} \quad H(z)$$

$$z^n \rightarrow H(z) z^n$$

$$H(z) = \sum_{n=-\infty}^{\infty} h[n] z^{-n}$$

z-Transform

$$X(z) = \sum_{n=-\infty}^{\infty} x[n] z^{-n}$$

$$x[n] \xleftrightarrow{Z} X(z)$$

$$X(\omega) = \sum_{n=-\infty}^{\infty} x[n] e^{-j\omega n}$$

$$X(z) = \sum_{n=-\infty}^{\infty} x[n] z^{-n}$$

$$z = r e^{j\omega}$$

$$\underbrace{X(z)}_{X(e^{j\omega})} \Big|_{z=e^{j\omega}} = \underbrace{\mathcal{F}\{x[n]\}}_{X(\omega)}$$

New Notation

$$\mathcal{F}\{x[n]\} = X(e^{j\omega})$$

MARKERBOARD  
22.2 (a)

$$X(z) \Big|_{z=e^{j\omega}} = X(e^{j\omega})$$

$$X(z) = \sum_{n=-\infty}^{\infty} x[n] z^{-n}$$

$$X(re^{j\omega}) = \sum_{n=-\infty}^{\infty} x[n] \underbrace{(re^{j\omega})^{-n}}_{r^{-n} e^{-j\omega n}}$$

$$= \sum_{n=-\infty}^{\infty} x[n] r^{-n} e^{-j\omega n}$$

$$X(z) = \mathcal{F}\{x[n] r^{-n}\}$$

Example 10.1

$$x[n] = a^n u[n]$$

$$X(e^{j\omega}) = \frac{1}{1 - a e^{j\omega}} \quad |a| < 1$$

$$X(z) = \sum_{n=0}^{\infty} \frac{a^n z^{-n} u[n]}{(a z^{-1})^n}$$

$$= \frac{1}{1 - a z^{-1}} \quad |a z^{-1}| < 1$$

$$\quad \quad \quad |a r^{-1}| < 1$$

$$a^n u[n] \xleftrightarrow{Z} \frac{1}{1 - a z^{-1}} \quad |z| > |a|$$

ROC

Example 10.2

$$-a^n u[-n-1] \xleftrightarrow{Z} \frac{1}{1 - a z^{-1}} \quad |z| < |a|$$

ROC

Inverse z-Transform

$$X(z) = \mathcal{F}\{x[n] r^{-n}\}$$

$$x[n] r^{-n} = \mathcal{F}^{-1}\{X(z)\}$$

$$= \frac{1}{2\pi} \int_{-\pi}^{\pi} X(re^{j\omega}) e^{j\omega n} d\omega$$

$$x[n] = \frac{1}{2\pi} \int_{-\pi}^{\pi} X(re^{j\omega}) \underbrace{(re^{j\omega})^{-n}}_z \underbrace{e^{j\omega n}}_{z^n} d\omega$$

$$z = r e^{j\omega} \quad d\omega = \frac{dz}{j z}$$

$$x[n] = \frac{1}{2\pi j} \oint X(z) z^{n-1} dz$$

TRANSPARENCY  
22.1  
The  $z$ -plane and the unit circle.

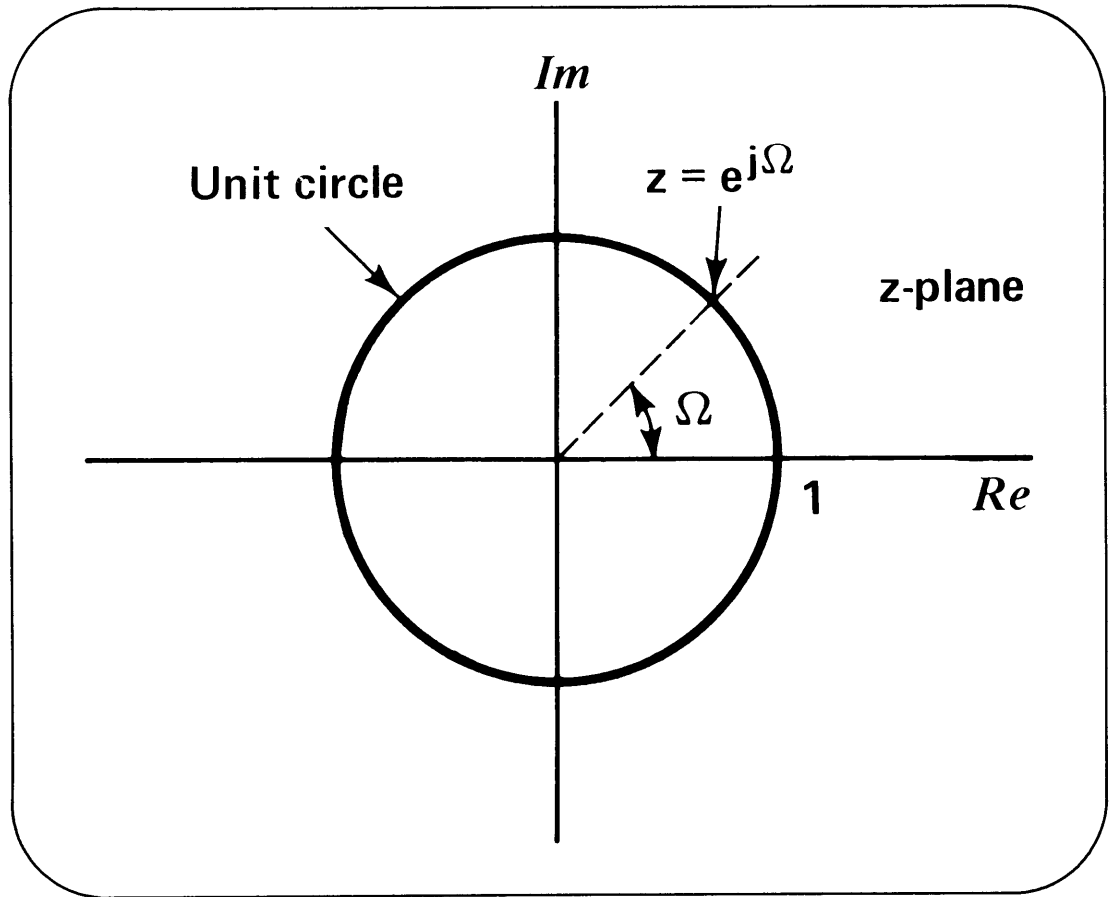

TRANSPARENCY  
22.2  
The  $z$ -transform and associated pole-zero plot for a right-sided exponential sequence.

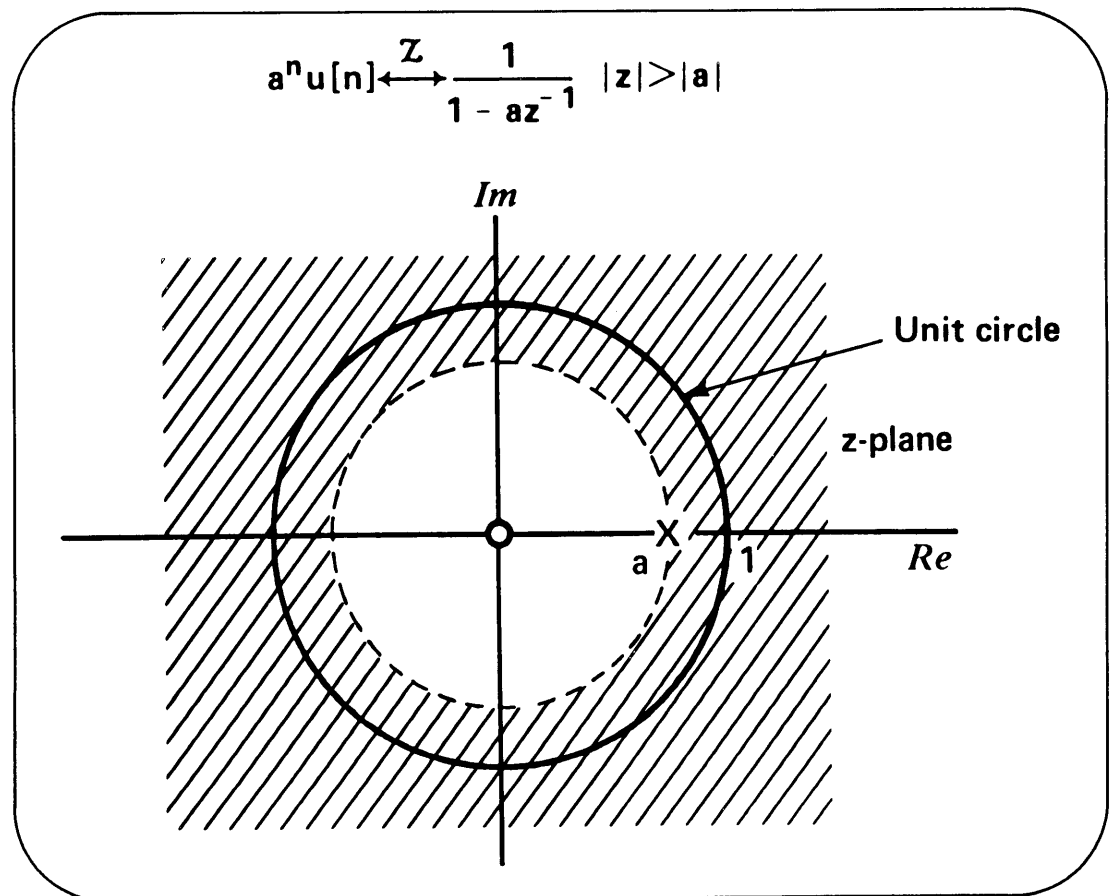

$$-a^n u[-n-1] \xleftrightarrow{Z} \frac{1}{1 - az^{-1}} \quad |z| < |a|$$

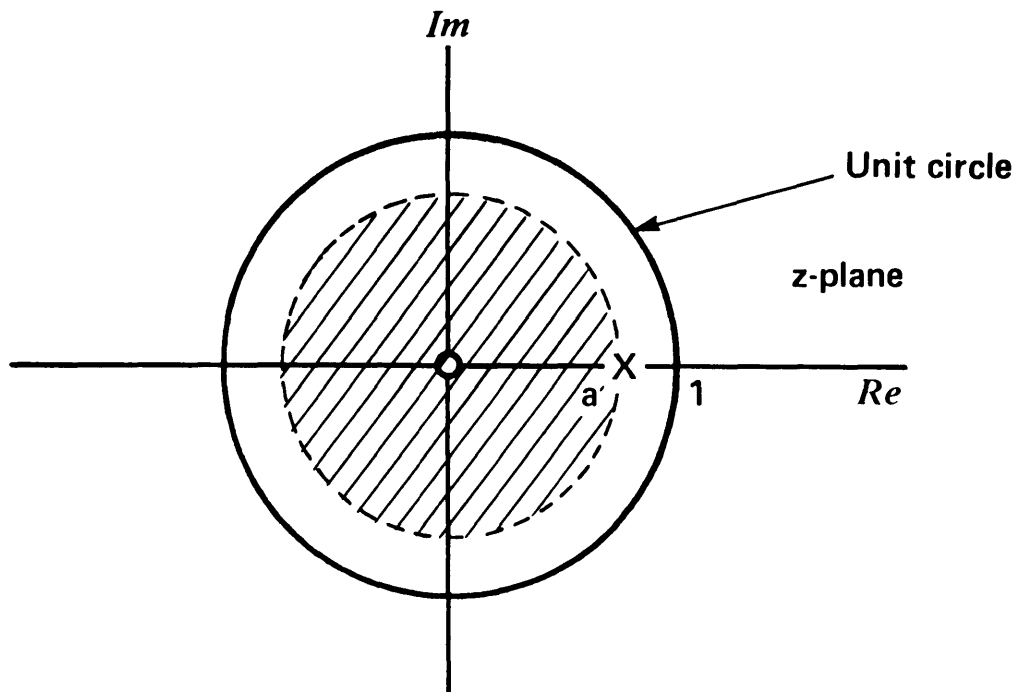

**TRANSPARENCY 22.3**  
The z-transform and associated pole-zero plot for a left-sided exponential sequence.

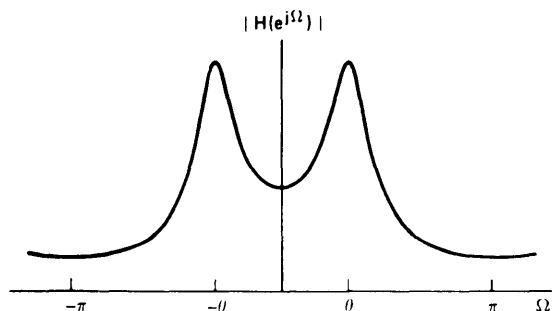
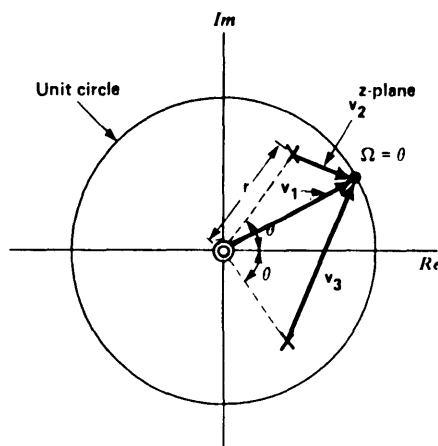

**TRANSPARENCY 22.4**  
Pole-zero plot for a discrete-time underdamped second-order system illustrating the geometric determination of the Fourier transform from the pole-zero plot.

TRANSPARENCY  
22.5  
Properties of the ROC  
of the  $z$ -transform.

### PROPERTIES OF THE REGION OF CONVERGENCE

- The ROC does not contain poles
- The ROC of  $X(z)$  consists of a ring in the  $z$ -plane centered about the origin
- $\mathcal{F}\{x[n]\}$  converges  $\Leftrightarrow$  ROC includes the unit circle in the  $z$ -plane
- $x[n]$  finite duration  $\Rightarrow$  ROC is entire  $z$ -plane with the possible exception of  $z = 0$  or  $z = \infty$

TRANSPARENCY  
22.6  
Properties of the ROC  
for a right-sided  
sequence.

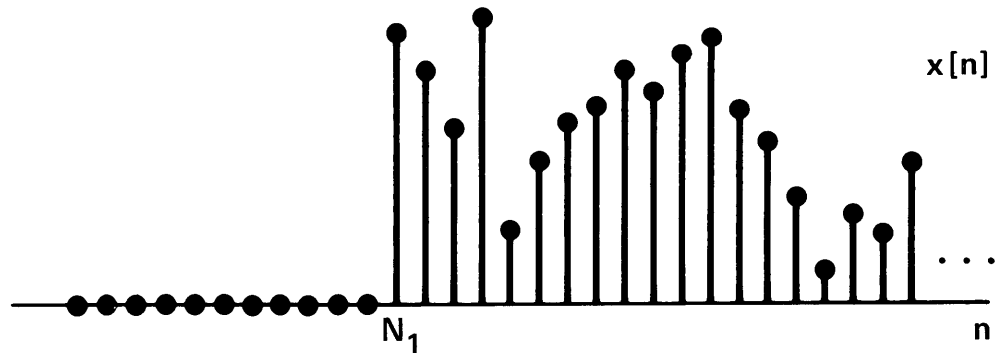

- $x[n]$  right-sided and  $|z| = r_0$  is in ROC  
 $\Rightarrow$  all finite values of  $z$  for which  $|z| > r_0$   
are in ROC
- $x[n]$  right-sided and  $X(z)$  rational  
 $\Rightarrow$  ROC is outside the outermost pole

- $x[n]$  left-sided and  $|z| = r_o$  is in ROC  
 $\Rightarrow$  all values of  $z$  for which  $0 < |z| < r_o$   
 will also be in ROC
- $x[n]$  left-sided and  $X(z)$  rational  
 $\Rightarrow$  ROC inside the innermost pole
- $x[n]$  two-sided and  $|z| = r_o$  is in ROC  
 $\Rightarrow$  ROC is a ring in the  $z$ -plane which  
 includes the circle  $|z| = r_o$

**TRANSPARENCY**  
22.7

Properties of the ROC of the  $z$ -transform for a left-sided sequence and for a two-sided sequence.

$$X(z) = \frac{z}{(z - \frac{1}{3})(z - 2)}$$

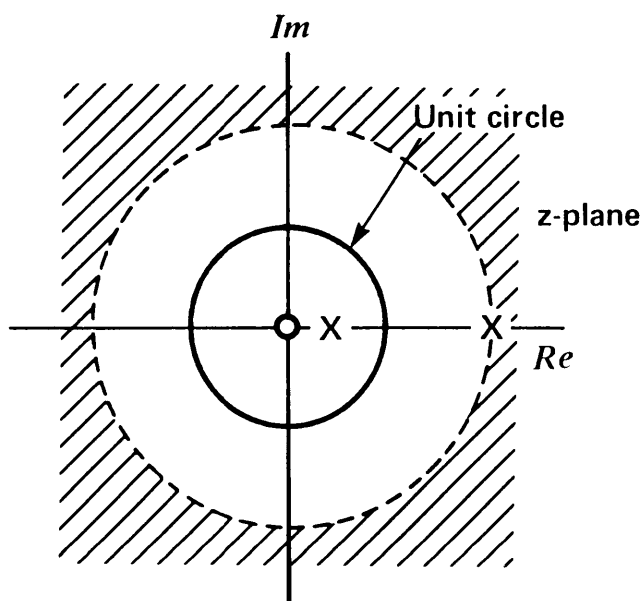

**TRANSPARENCY**  
22.8

Transparencies 22.8–22.10 show ROCs for a specified algebraic expression for the  $z$ -transform. Shown here is the ROC if the sequence is right-sided.

TRANSPARENCY

22.9

The ROC if the sequence is left-sided.

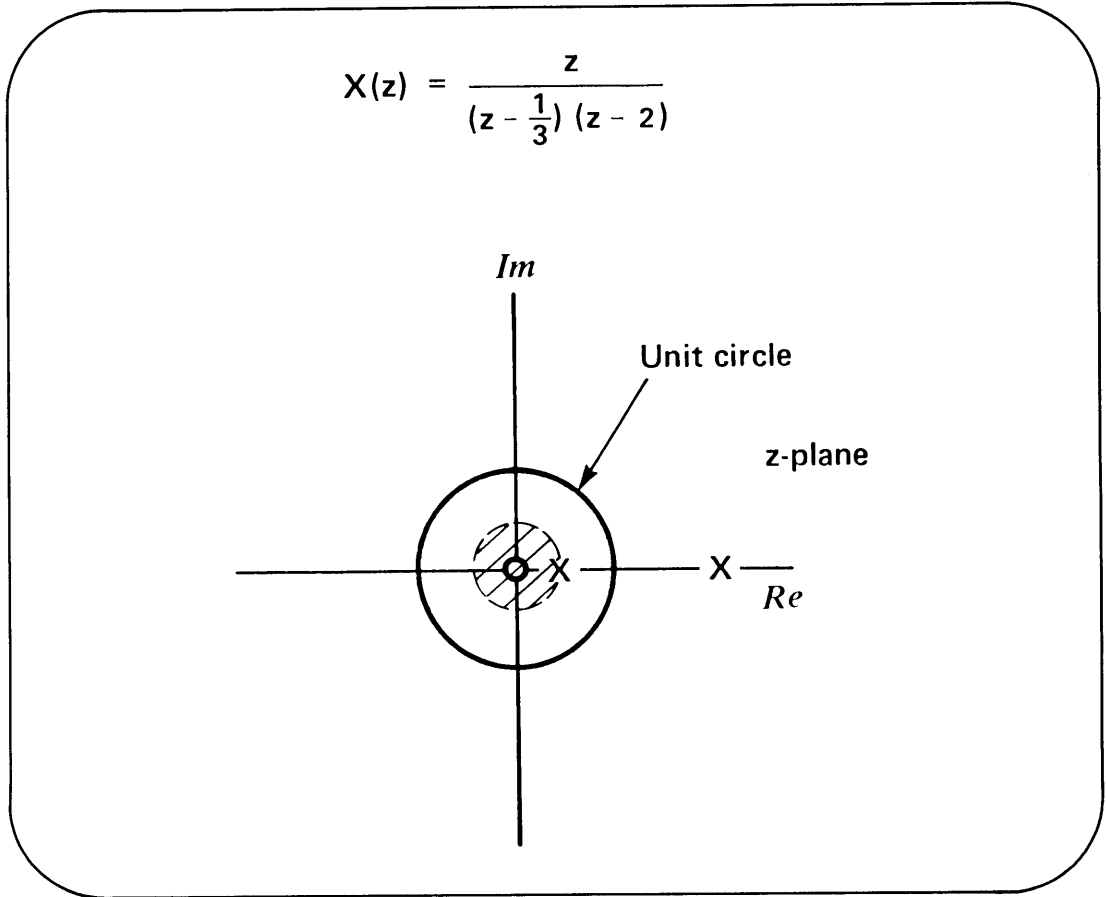

TRANSPARENCY

22.10

The ROC if the sequence is two-sided.

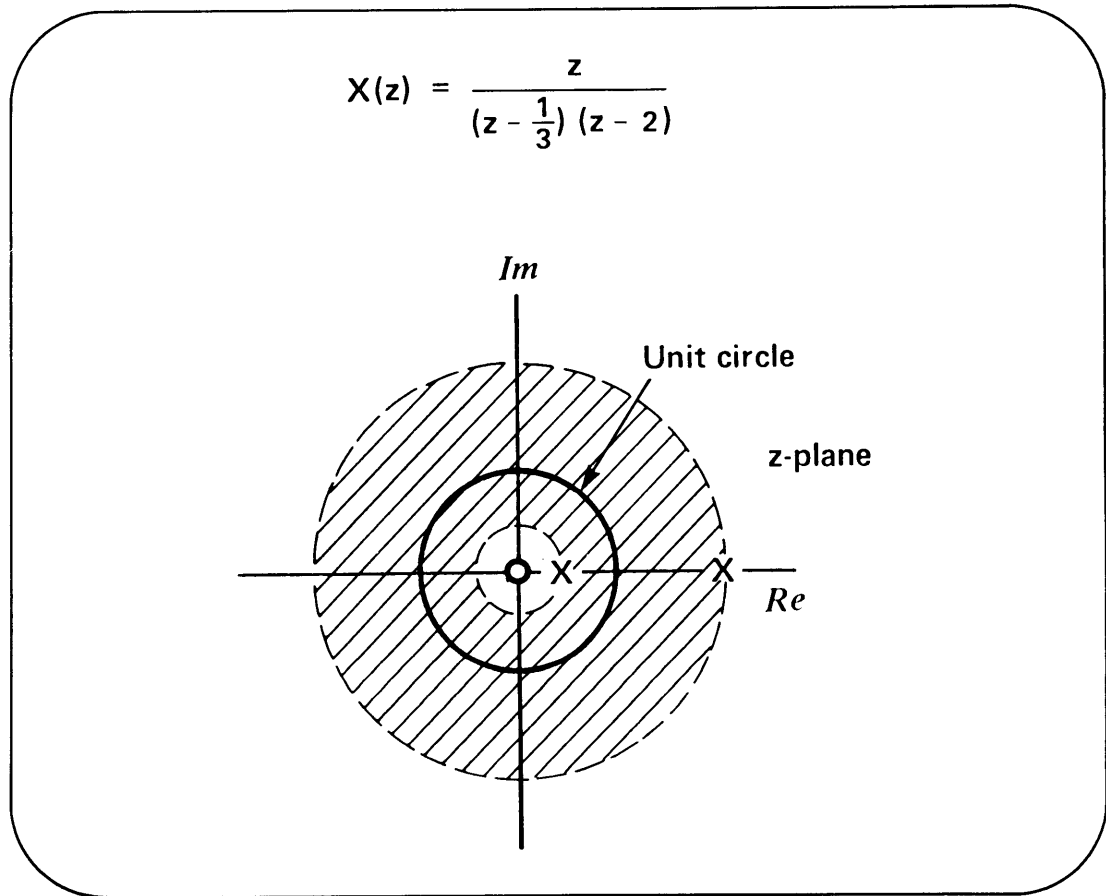



**MARKERBOARD**  
 22.2 (b)

$$\mathcal{X}(z) \Big|_{z=e^{j\Omega}} = \mathcal{X}(e^{j\Omega})$$

$$\mathcal{X}(z) = \sum_{n=-\infty}^{+\infty} x[n] z^{-n}$$

$$\mathcal{X}(re^{j\Omega}) = \sum_{n=-\infty}^{+\infty} x[n] \underbrace{(re^{j\Omega})^{-n}}_{r^{-n} e^{-j\Omega n}}$$

$$= \sum_{n=-\infty}^{+\infty} x[n] r^{-n} e^{-j\Omega n}$$

$$\mathcal{X}(z) = \mathcal{F}\{x[n] r^{-n}\}$$

Example 10.1

$$x[n] = a^n u[n]$$

$$\mathcal{X}(e^{j\Omega}) = \frac{1}{1 - ae^{j\Omega}} \quad |a| < 1$$

$$\begin{aligned} \mathcal{X}(z) &= \sum_{n=0}^{+\infty} \frac{a^n z^{-n} u[n]}{(az^{-1})^n} \\ &= \frac{1}{1 - az^{-1}} \quad |az^{-1}| < 1 \\ &\quad |ar^{-1}| < 1 \end{aligned}$$

$$a^n u[n] \leftrightarrow \frac{1}{1 - az^{-1}} \quad |z| > |a|$$

ROC

Example 10.2

$$-a^n u[n-1] \leftrightarrow \frac{1}{1 - az^{-1}} \quad |z| < |a|$$

ROC

Inverse z-Transform

$$\mathcal{X}(z) = \mathcal{F}\{x[n] r^{-n}\}$$

$$\begin{aligned} x[n] r^{-n} &= \mathcal{F}^{-1}\{\mathcal{X}(z)\} \\ &= \frac{1}{2\pi} \int_{-\pi}^{\pi} \mathcal{X}(re^{j\Omega}) e^{j\Omega n} d\Omega \end{aligned}$$

$$x[n] = \frac{1}{2\pi} \int_{-\pi}^{\pi} \underbrace{\mathcal{X}(re^{j\Omega})}_{\mathcal{X}(z)} \underbrace{(re^{j\Omega})^n}_{z^n} d\Omega$$

$$z = re^{j\Omega} \quad dz = jre^{j\Omega} d\Omega$$

$$x[n] = \frac{1}{2\pi j} \oint \mathcal{X}(z) z^{n-1} dz$$

**MARKERBOARD**  
 22.3

Partial Fractions

$$\mathcal{X}(z) = \frac{3}{(z-\frac{1}{3})(z-2)} \quad |z| > 2$$

$$= \frac{3^{-1}}{(1-\frac{1}{3}z^{-1})(1-2z^{-1})} \quad |z| > 2$$

$$= \frac{-3/5}{(1-\frac{1}{3}z^{-1})} + \frac{3/5}{(1-2z^{-1})} \quad |z| > 2$$

$$= -\frac{3}{5} \left(\frac{1}{3}\right)^n u[n] + \frac{3}{5} (2)^n u[n]$$

Power Series

$$\mathcal{X}(z) = \sum_{n=-\infty}^{+\infty} x[n] z^{-n}$$

$$\frac{1}{1 - az^{-1}} = \frac{1}{1 - az^{-1}} \left[ \frac{1 + az^{-1} + \dots}{1 - az^{-1}} \right]$$

$$\frac{1}{1 - az^{-1}} = 1 + az^{-1} + a^2 z^{-2} + \dots$$

$$x[n] = a^n u[n]$$

MIT OpenCourseWare  
<http://ocw.mit.edu>

**Resource: Signals and Systems**  
Professor Alan V. Oppenheim

The following may not correspond to a particular course on MIT OpenCourseWare, but has been provided by the author as an individual learning resource.

For information about citing these materials or our Terms of Use, visit: <http://ocw.mit.edu/terms>.